

©くまみね

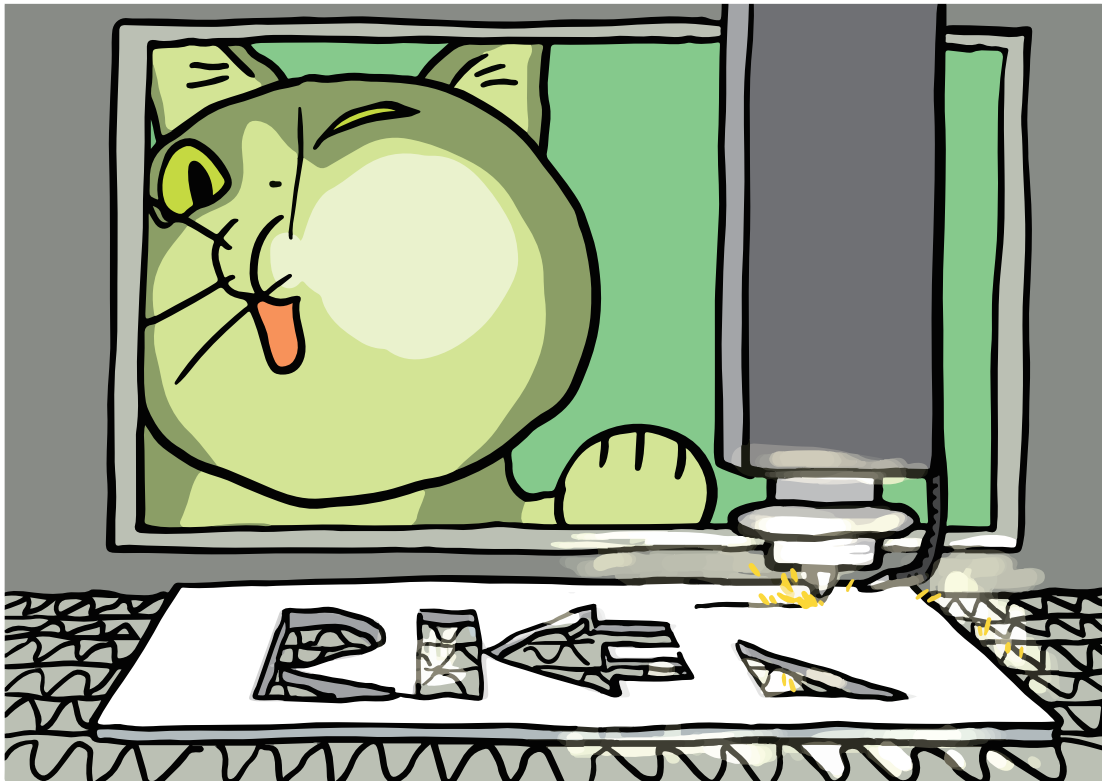

Things To Know

Fiber Laser Safety Measures

—Selected Content—



RIKEN OPTECH CORPORATION

Start with the safety measures of laser light

Basic ideas for safety countermeasures against laser light

- 1st** **Do not allow the laser light to leak outside.**
It is necessary to take appropriate safety measures, such as setting up partitions, to adjust the environment.
- 2nd** **Consider methods that do not directly observe the laser light to reduce direct exposure.**
For example, visual confirmation by means of a laser filter or the use of alternative methods such as a camera may be considered.
- Lastly** **Use personal protective gear**
Use appropriate personal protective equipment when working, especially in high energy laser processing or precision process work.

The characteristics of laser: Strong linearity, and not easy to diffuse

- Directivity** The beam from the laser is almost undiffused and travels in a straight line. In contrast, the light from an ordinary lamp spreads out in all directions.
- Monochromaticity** Laser is a pure monochromatic light (wavelength and frequency), because it is a single wavelength, the energy density is high. In contrast, the light emitted by ordinary lamps is composed of a mixture of complex colors.
- Interference** Because the light wave phase (wave peak and wave trough) of the laser is consistent in time, it has good interference (interference). By synthesizing these waves, a wave with a larger amplitude (larger output power) can be obtained.

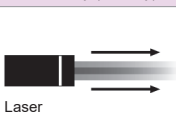
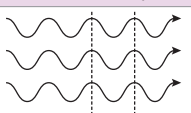
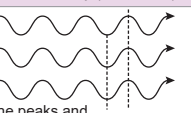
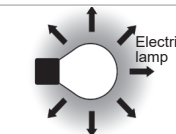
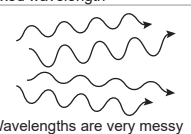
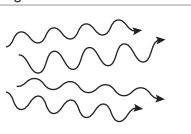
	Directivity (linearity)	Monochromaticity	Interferability (coherence)
Laser			
Ordinary light			

The characteristics of laser: Pay attention to reflected and scattered light

When laser light irradiates an object, the following four phenomena will inevitably occur:

- Absorption** Light is converted into heat energy.
- Reflection** The reflection increases when the surface is smooth and decreases when the surface is rough. **Notice!**
- Scattering** Scattering increases when the surface is rough and decreases when the surface is smooth. **Notice!**
- Penetration** Light that passes through an object without being absorbed, reflected, or scattered.

- ✓ In most cases, more than two phenomena occur simultaneously.
- ✓ The light will continue to propagate until it is absorbed.
- ✓ In the laser processing site, special attention should be paid to **reflected light** and **scattered light!**

In laser processing, a large amount of reflected light and scattered light often occur around the processing point directly irradiated by laser light. Not limited to the vicinity of the processing point, the reflected and scattered laser light may be scattered in unexpected directions after being reflected many times at different locations. Although the intensity of the reflected light is reduced compared to the total output power, it is still dangerous enough for the eyes. Therefore, not only the direct operator needs to be protected, but also the person entering the work site or nearby area needs to take protective measures.

Danger of laser light

The harm of laser light to the eyes

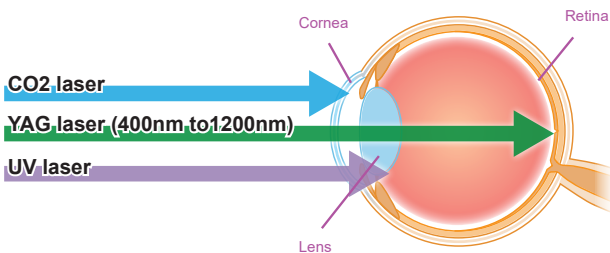

- CO2 laser** Energy is concentrated on the surface of the cornea, which may cause burns and so on.
- YAG laser (400nm to 1200nm)** The cornea and lens hardly absorb the laser, and the laser may damage the fundus. (Because the retina does not have the ability to repair itself, it is easy to cause serious consequences after injury.)
- UV laser** At shorter wavelengths, the laser light is absorbed by the cornea and lens, which may cause corneal burns or cataracts, accompanied by decreased vision.

Lasers include visible lasers that are visible to the human eye and invisible lasers that are invisible. Lasers used for laser processing are mostly invisible lasers, such as CO2 lasers and YAG lasers, among which there are also high-power and dangerous lasers. With different laser wavelengths, the damaged parts of the eyes will also be different. If the eye is damaged by the laser (due to the low recovery capacity of the eye), permanent visual impairment may result.

What is the OD value (optical density)?

Optical Density ▶▶ OD value

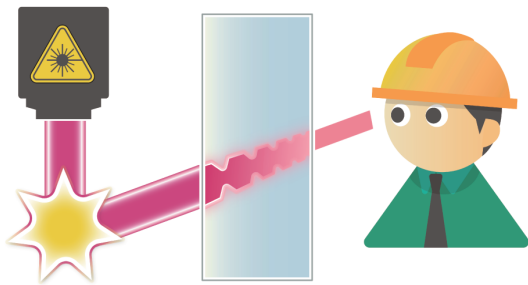

The amount of light transmission is expressed in transmittance %. For a particular wavelength of light, such as laser light, the more it is absorbed (the transmittance is close to zero), the safer it is for the eye.

The OD value indicates the degree of absorption and attenuation by logarithm, and the relationship between the OD value and the transmittance % is as follows:

Optical Density (OD)	Attenuation rate	Transmittance (%)
0	0	100
1	1/10	10
2	1/100	1
3	1/1000	0.1
4	1/10000	0.01
5	1/100000	0.001
6	1/1000000	0.0001

High safety

POINT

✓ The larger the OD value, the lower the transmittance at the specified wavelength.

In other words The laser light is blocked by the lens or filter of the shield.

So The safety becomes high.

What is MPE (Maximum Permissible Exposure)?

Maximum Permissible Exposure ▶▶ MPE value

Definition

The maximum level of laser radiation that does not produce harmful effects when exposed to the human body under normal circumstances.

POINT

✓ MPE refers to the amount of radiation that is 1/10 of the amount of damage to the human body (skin or retina) with a 50% probability.

✓ Based on the MPE, the AEL (Accessible Emission Limit) for laser classification is set.

What is the AEL (Accessible Emission Limit)?

Accessible Emission Limit ▶▶ AEL value

Definition

The maximum exposure emission level allowed in the laser product classification.

POINT

✓ Check the AEL specified by the safety class to which the laser belongs (e.g. 1, 2, 3 B, etc.), beyond which the laser will not be emitted.

✓ The manufacturer of the laser equipment must carry out the evaluation using the specified measurement method and the appropriate classification identification in all operating modes where the performance permits.

JIS C 6802 (Classification of laser products)

Classification	Hazard Assessment Overview	Necessity of laser goggles
Class 1	A laser that is considered safe under normal operating conditions (reasonably foreseeable operating conditions).	△
Class 1M	Laser light in the wavelength range of 302.5 to 4,000nm. Direct observation of laser light with optical instruments may be potentially hazardous. The radiation level of the laser is the same as Class1.	△
Class 2	Laser light in the wavelength range of 400 to 700nm, which is visible laser light, usually provides adequate protection through the eye's natural aversion response (blinking).	△
Class 2M	Laser light in the wavelength range of 400 to 700nm, similar to Class2, usually provides adequate protection through the eye's natural aversive response (blinking).However, direct observation of laser light using optical instruments can be potentially dangerous.	△
Class 3R	Laser light in the wavelength range of 302.5nm to 10 ⁶ nm. Direct observation of the beam may be potentially hazardous.	○*
Class 3B	Direct observation of a laser beam is always considered dangerous, but it is generally considered safe for diffuse reflected light.	○
Class 4	Even if temporary, direct exposure to the laser beam is considered dangerous to the skin and eyes, and even diffuse reflected light may cause damage to the skin and eyes, and is considered a potential risk of fire.	○

△ : It is safer to suggest the use of goggles.
(This is not a mandatory measure in the JIS standard.)

○ : Goggles must be used.(This is a mandatory measure in the JIS standard.)

* In Class 3R, protective eyewear is mandatory except for wavelengths from 400 to 700nm.

Personal protective equipment

Laser protective goggles (with bright and easy-to-see glass lenses)



Glass lenses that are bright and easy to see



RSX-4 YG-SG

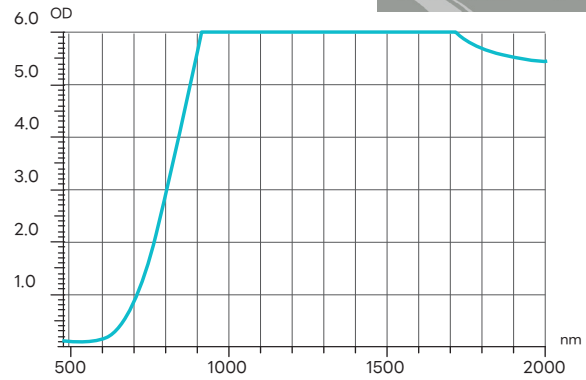

Applicable wavelength range (nm)	OD value	Visible light transmittance
925-999	5	70%
1,000-1,024	6	
1,025-1,400	7	

Heat & Scratch Resistant

Designed for demanding fiber laser environments, these glass lenses deliver excellent resistance to heat and surface damage. Their high durability reduces replacement frequency, helping lower running costs and maintain stable performance.

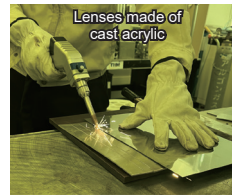

Photo Collaboration: THM Ltd.

Laser Safety Glasses with Protective Gasket

Outstanding Anti-Fog Performance
Designed for both safety and comfort.



RC-170 FB-EP

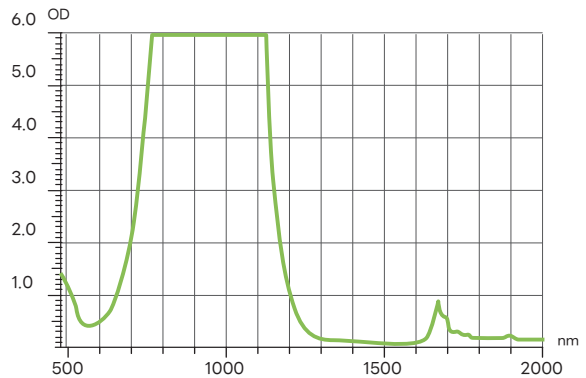

Applicable wavelength range (nm)	OD value	Visible light transmittance
860-1,100	6	30%

Outstanding Anti-Fog Performance.

Dual-sided VF-Plus+ anti-fog coating keeps vision clear. Blocks 99.9% of UV rays and resists scratches for long-lasting durability.

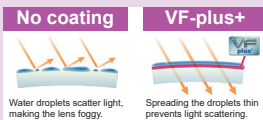

Secure, Slip-Resistant Fit

The bridge-supported design helps prevent slipping and provides a comfortable fit regardless of nose shape or height. Also designed for easy use with face masks.

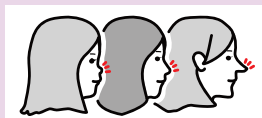

Sealed Gap Protection

A soft, face-conforming gasket seals gaps between the face and lens. Effectively blocks stray laser light and dust.



Goggles for laser (covering goggles that can be worn directly over corrective spectacles)

An enhanced protection model for high-power fiber laser applications.



RS-80 YG-EP

-  UV protection
-  Suitable for corrective spectacles
-  Adjusted angle
-  Telescopic adjustment
- 

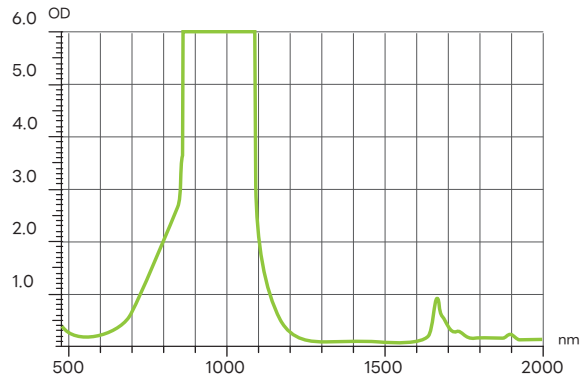

Applicable wavelength range (nm)	OD value	Visible light transmittance
860-1,100	6	64%

A versatile standard model for general fiber laser use.



RS-80 YG

-  UV protection
-  Suitable for corrective spectacles
-  Adjusted angle
-  Telescopic adjustment

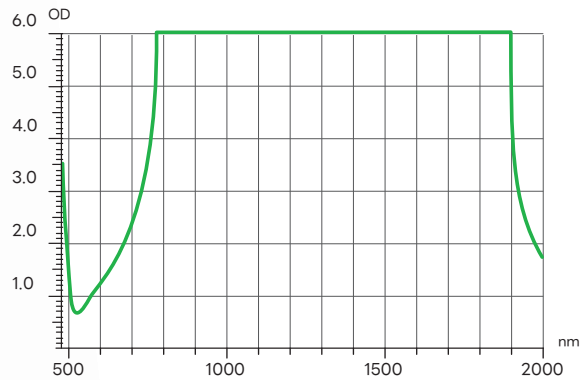

Applicable wavelength range (nm)	OD value	Visible light transmittance
800-1,800	6	4%

A multi-wavelength model designed for versatile laser applications.



RS-80 TWCL

-  UV protection
-  Suitable for corrective spectacles
-  Adjusted angle
-  Telescopic adjustment

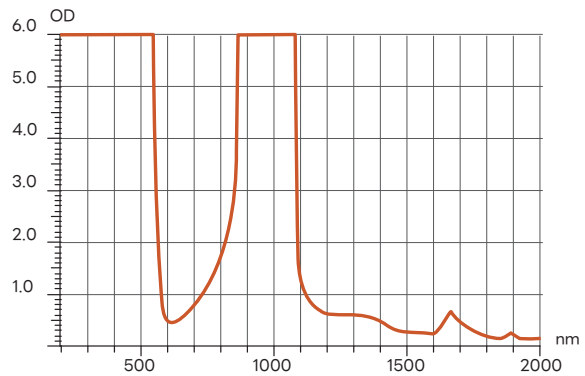

Applicable wavelength range (nm)	OD value	Visible light transmittance
200-524	6	37%
525-537(532)	5	
860-1,090	6	

Protective equipment for surrounding environment

Protective filter for laser

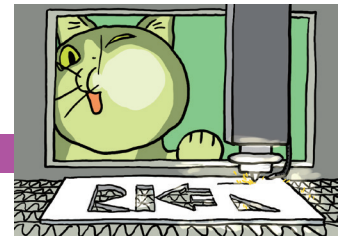

Glass filter that is bright and easy to see



RLF-YG-SG

Applicable wavelength range (nm)	OD value	Visible light transmittance
925-999	6	66%
1,000-1,024	6	
1,025-1,400	8	

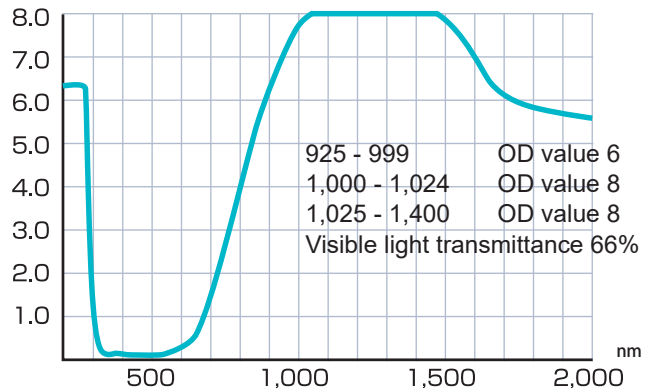

Maximum standard size 297×210×4.2t

Acrylic filter for fiber laser



RLF-YG



Applicable wavelength range (nm)	OD value	Visible light transmittance
900~1,200	6	38%

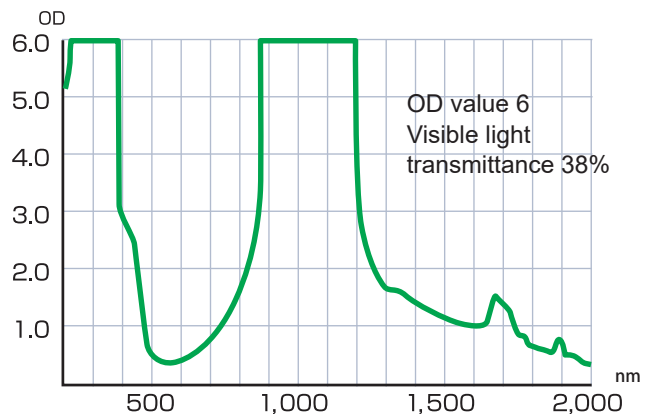

Maximum standard size 1,400×1,200×3.5t

Compatible with multiple wavelengths



RLF-TWCL

Applicable wavelength range (nm)	OD value	Visible light transmittance
200~540	6	13%
900~1,200		

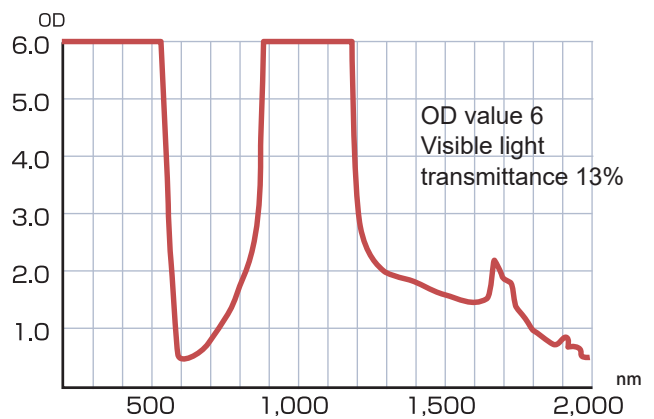

Maximum standard size 1,400×1,200×3.5t

Laser isolation panel

It is very suitable for the safety management of laser operation, especially for the scene of single operation!



Features of laser isolation panel

It is made of fluorine-free, non-combustible and heat-insulating color steel plate with superior wear resistance and impact resistance.

The connection seam of the panel adopts a special embedded structure to ensure that there is no gap, which can effectively prevent laser leakage.

The foot can be rotated and placed parallel to the wall or door.

Cost effective!



Customers can install it by themselves without the cost of installation.

Security!



Not only are flame retardant materials used, but the structure is also designed for laser safety.

Easy to use!



Equipped with casters for easy mobility! The laser management area can be easily set.



Fluorine-free non-combustible heat insulation color steel plate

**Ministry of Land, Infrastructure, Transport and Tourism of Japan
Non-Combustible Material Certification Number: NM-4907, NM-4907-1**

The laser isolation panel is made of "non-combustible materials" specified by the Ministry of Land, Infrastructure, Transport and Tourism of Japan in accordance with the Building Standards Law. In addition to non-combustible materials, there are "quasi-non-combustible materials" and "fire-resistant materials", among which non-combustible materials have the highest fire performance.



What is a non-combustible material?

Non-combustible materials are materials that can not start burning within 20 minutes in case of fire. Specifically, the material can maintain the following conditions for 20 minutes. Similarly, materials that require more than 10 minutes for "quasi-incombustible materials" and more than 5 minutes for "non-combustible materials" to maintain these conditions are considered to be of the corresponding grade.

- ◆ Material does not burn
- ◆ No deformation, melting, cracking, or other damage due to fire problems
- ◆ No harmful smoke or gas will be produced to endanger escape

Panel details

◆ Surface material

Color steel plate, Polyester fiber system (synthetic resin coated steel plate)/Panel thickness: 0.5mm/Color: light gray/Material standard: JIS: G3321

◆ Insulation material (core material)

Polyisocyanurate foam

◆ Basic dimensions

Thickness: 43mm/Width: 900mm/Height: 2,000mm

Laser safety structure design

Wall panel

The special fitting structure is firmly fixed by wedges, so there is no gap.



Corner panel

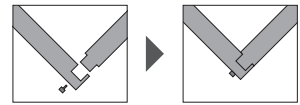
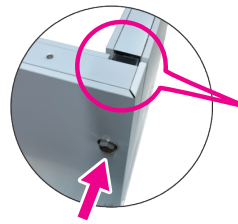

With a special embedding structure, it is firmly fixed by screws, so there is no gap.

Basic installation scenario example

Different parts can be combined for customization

Scenario A

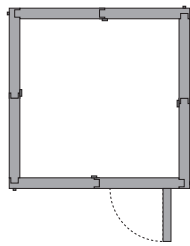
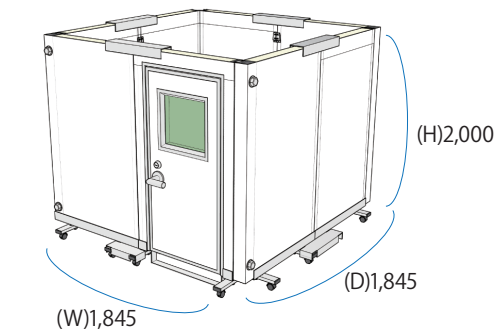

Specification

Land occupation area	1,845×1,845mm
Door	Hinged door
Observation window	1
Filter	RLF-YG
Lower part of the panel	With casters (storable)
Suggested retail price	1,500,000 yen

*Shipping is not included

Scenario B

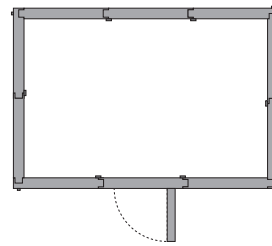
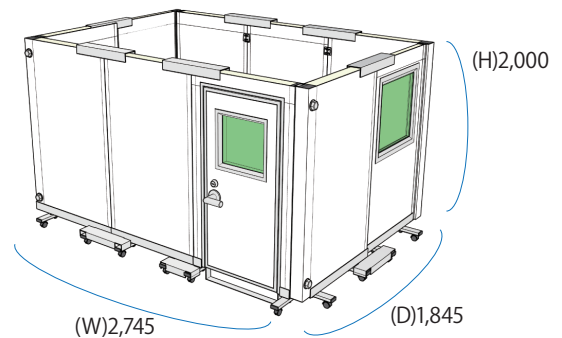

Specification

Land occupation area	2,745×1,845mm
Door	Hinged door
Observation window	2
Filter	RLF-YG
Lower part of the panel	With casters (storable)
Suggested retail price	1,800,000 yen

*Shipping is not included

Customizable parts



Wall panel

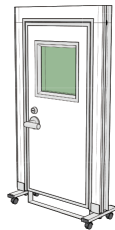

Door panel

(With 400 × 400mm laser filter)



Corner panel

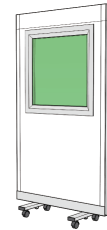

Wall panel with window

(With 600 × 600mm laser filter)

Are you experiencing any of the following problems?

- ① You want laser safety, but don't know where to start.
- ② You want to know how much it will cost.
- ③ You're not sure which wavelength to choose.
- ④ You want to consult the size of cutting or hole processing.

If you have any questions, please feel free to contact us. We will answer your questions about laser safety.

 **RIKEN OPTECH CORPORATION**

Headquarters address:
2-6-9 Higashi-Oi, Shinagawa-ku, Tokyo 140-8533
Website: <https://rikenoptech.com>

*The appearance and specifications of the product described in this manual are subject to change without notice.

*The color in this manual may be different from the actual product due to printing reasons, please understand.